

Hazard Warnings

Hazard warnings in this manual indicate potential harm to the user or the product. For the person interacting with the product, the level of risk includes consequences ranging from slight, up to lethal injuries. As for the product, disobeying the warnings may cause damage to the equipment and/or void the warranty. Therefore, said warnings are made apparent to instruct and warn the user, which precautions have to be made prior to performing any actions described in this manual. The user must read and be familiar with the manual, before performing any tasks as described in this manual.

Hazard warnings in this manual are presented in these three forms:

WARNING: These warning notices refer to personal safety. Failure to obey these notices could result in personal injury or death.



WARNING

CAUTION: General precautions must be made. Failure to obey these notices could result in personal injury and/or equipment damage.



CAUTION

NOTE: Directs the user's attention to essential information.

Operation manual for linear units type L

1 General

Linear units are offered in different variants, see Table 1. These are mounted together with electric open/close or modulating actuators, of the series AB or CM, on valves which require a linear positioning movement. The linear unit converts the torque output from the actuator into an axial force. The combination of actuator and linear unit, is based on the required thrust and the necessary stroke.

Type	Actuator	Output flange	Stroke	Output thread	Pitch	Factor ($\frac{Nm}{kN}$)	Weight [kg]
L50	AB3/5, CM03	G0/F10	50mm	M16x1,5	4mm/rev	2	3,9
L75	AB3/5, CM03	G0/F10	75mm	M16x1,5	4mm/rev	2	5,5
	CM06						
	AB8, CM12						
L100	AB3/5, CM03	G0/F10	100mm	M16x1,5	4mm/rev	2	6,2
	CM06						
	AB8, CM12						
L350	AB3/5	G0/F10	350mm	M24x2,0	5mm/rev	2,43	15
	CM06						
	AB8, CM12						
L500	AB3/5	G0/F10	500mm	M24x2,0	10mm/rev	3,62	19
	AB3/5/8						
	AB8, CM12						
L200. CM03.01	CM03	G0/F10	200mm	M16x1,5	4mm/U	2	15
L200.5	AB3/5	G0/F10	200mm	M16x1,5	5mm/rev	2,44	15
L200.8	AB8	G0/F10	200mm	M16x1,5	5mm/rev	2,44	15
L100.8	AB8, CM12	G0/F10	100mm	M16x1,5	5mm/rev	2,73	14
L120.18	AB18	G $\frac{1}{2}$ /F14	120mm	M36x3,0	6mm/rev	3,16	28
L220.18	AB18	G $\frac{1}{2}$ /F14	220mm	M36x3,0	6mm/rev	3,16	30
L150.40	AB40	G $\frac{1}{2}$ /F14	150mm	M36x3,0	7mm/rev	4,45	39
L300.40	AB40	G $\frac{1}{2}$ /F14	300mm	M36x3,0	7mm/rev	4,45	43
L100.100	AB100	G3/F16	100mm	M42x3,0	8mm/rev	4,61	110
L200.100	AB100	G3/F16	200mm	M42x3,0	8mm/rev	4,61	120
L200.200	AB200	G4/F25	200mm	M48x3,0	9mm/rev	5,64	150

Table 1: Technical data linear units

2 Structure

Figure 1 shows e.g. an CM03 actuator with mounted L75 linear unit. The linear units can also be combined with actuators of the AB series. The linear unit itself consists essentially of a solid cast housing, a mounted spindle nut and a non-rotating spindle, see Figure 2. To prevent contamination by dusty ambient air and to ensure the mechanical protection, the linear unit is provided with a bellows at the output.



Figure 1: CM03-Actuator with mounted L75 linear unit

Figure 2 shows the exploded drawing of the linear unit. Through the key on the spindle and the groove in the housing of the linear unit, the rotation prevention of the spindle is ensured.

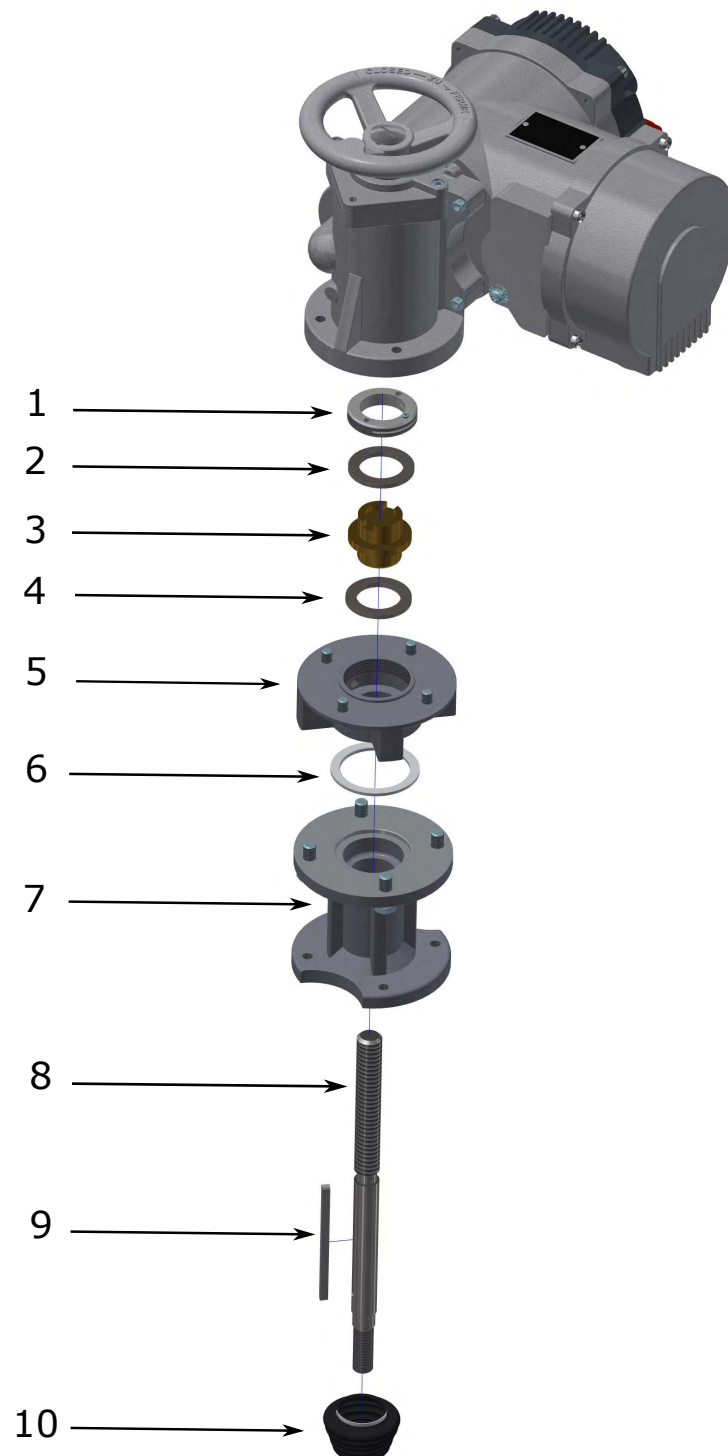

Figure 2: 1... Ring nut, 2... Axial bearing, 3... Spindle nut, 4... Axial bearing, 5... Output flange, 6... Centering ring, 7... Housing linear unit, 8... Spindle, 9... Key, 10... bellows

3 Packaging, transport and storage

See chapter „Packaging, transport and storage“ in der standard user manual.

4 Assembly and disassembly of linear units on valves

In the following two subsections, the procedures for assembly and disassembly of linear units on valves are explained step by step.

4.1 Security and assembly instructions

WARNING: For assembly and disassembly of the linear unit, the pipes where the valve is installed on have to be depressurised!



WARNING

WARNING: The device may only be mounted and commissioned by qualified personnel!

Qualified personnel within the meaning of this operating manual are persons who are familiar, with assembly, commissioning and operation of this product, and have the required appropriate qualifications for this activity.



WARNING

WARNING: Only in the retracted state of the linear unit is an end stop available - if the maximum stroke is exceeded in the extended state, the spindle moves out of its guidance!

Do not move against the end stop in electrical operation! The end limits of the actuator must be set accordingly!



WARNING

WARNING: Never bring the valve cone with excessive force in the CLOSED position. This can damage the high-quality sealing edges.



WARNING

4.2 Assembly

1. Check that the actuator flange, the linear unit flanges and the valve flange match.
2. Thoroughly clean screw-on surfaces and bare parts on actuator, linear unit and valve.
3. Lightly grease the connections of the actuator, the linear unit and the valve.
4. Grease the spindle of the linear unit.
5. Move the valve cone in the CLOSED position.
6. Turn the spindle nut until the linear unit is in a central position.
7. Mount the linear unit on the valve and tighten the screws crosswise. The coupling between the linear unit and the valve will be connected later.
8. Mount the actuator on the linear unit and tighten the screws crosswise.
9. Extend the spindle by rotating the handwheel until the coupling of the linear unit and the valve fit together.
10. Connect the coupling between linear unit and valve.
11. Use the handwheel to move the linear unit to a center position, to prevent accidental damage to the valve during startup.

4.3 Disassembly

1. If the valve is fully closed, move the valve cone to about ten percent OPEN position
2. Loosen the screws between the output flange of the actuator and the linear unit and dismount the actuator.
3. Open the spindle coupling between the linear unit and the valve.
4. Loosen the screws between the output flange of the linear unit and the valve.
5. Dismount the linear unit from the valve.

5 Commissioning

See chapter „Commissioning“ in the standard user manual.

6 Maintenance

Pay attention to increased running noises, occur on them, grease the two lubrication nipples of the linear unit to lubricate the bearings and the spindle guidance.

Check the clearance between the spindle and the spindle nut by pulling on the spindle with the spindle nut fixed. If a clear movement is possible, the ring nut may have loosened or the spindle nut has worn out. In the second case, an exchange of the spindle nut is recommended.

Regularly check the fixing screws between the actuator, the linear unit and the valve for firm hold, if necessary tighten them with the torques specified in chapter „Installation instructions“ of the standard user manual.

6.1 Service/Exchange of spindle nut and axial bearing

This service must be executed at regular intervals, depending on the operating mode:

Modulating operating mode:	5 years
Open/Close operating mode:	10 years

The following procedure is to be observed, the assignment of the components can be found in Figure 2:

1. If necessary, disassemble the actuator from the valve.
2. Disconnect the actuator from the linear unit.
3. Loosen the small worm screw in the ring nut.
4. Unscrew the ring nut from the output flange using a mortise key.
5. Remove the spindle nut and the two axial bearings.
6. Wash and clean them and remove all grease from the output flange.
7. Grease the cleaned or new components and reinsert them in the output flange in the order axial bearing, spindle nut and axial bearing.
8. Insert the ring nut again and turn it with the mortise key until it stops.
9. Turn the ring nut back a quarter turn, hold it with mortise key and fix the worm screw to secure the ring screw against twisting.
10. The ring nut must now no longer be able to turn with the mortise key.

6.2 Moving interval

The linear unit should be actuated at least every 3 months.

6.3 Greasing intervall

Every 6 months the linear unit should be re-greased via the greasing nipples .

7 Lubricant recommendation

Lubricating grease DIN 51825-K(P) R -40

i.e. Water-repellent complex grease based on Al-soap with high resistance to acids and alkalis:

Ambient Temperature:	-40 bis +85 °C
Worked penetration 0,1 mm:	310 - 340
Dripping point:	ca. 260 °C
NLGI-Class:	1
acid-free, not or only slightly reactive with water	